

# Installation Instructions

## K4312A

### 1994-1997.5 Ford 7.3L F250-F350 Cat Back Dual 4"

Tools needed: 9/16" end wrench or socket, 7/16" deep socket, hacksaw or sawzall, aerosol lubricant.  
**(If your vehicle is equipped with a catalytic converter, it is unlawful to remove.)**

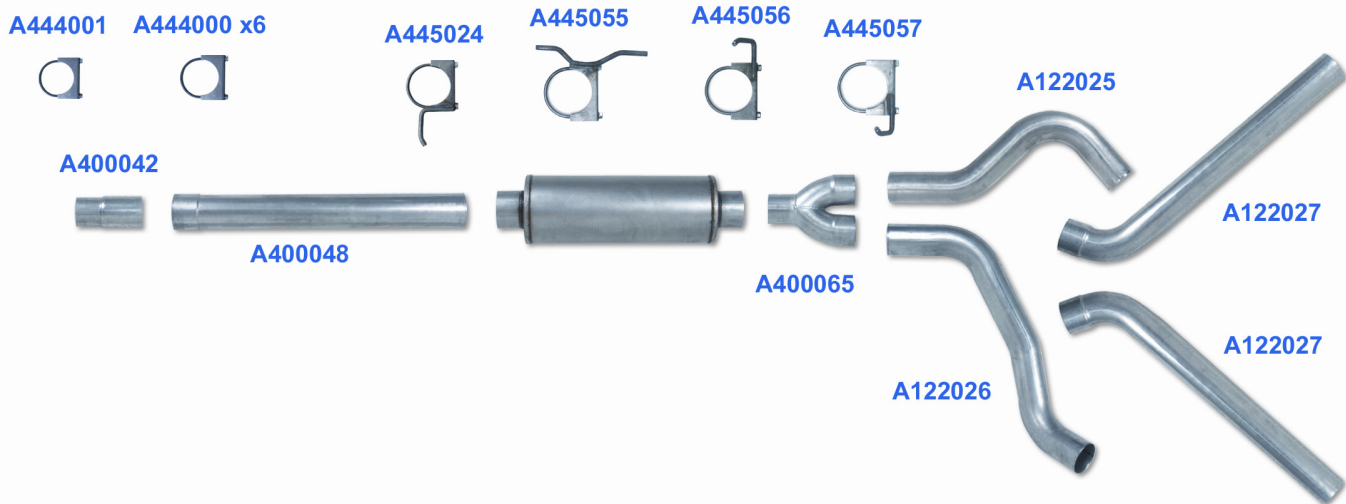

#### Removal of Original System

- 1) From under the truck, cut the intermediate pipe 4" behind the catalytic converter.
- 2) Cut the tail pipe just behind the muffler.
- 3) Spray the stock hanger points with aerosol lube and pry the system from the rubber mounts. Leave the rubber mounts attached to the truck for re-use.
- 4) Remove the old system.
- 5) Remove the spare tire and spare tire hanger brackets.

#### Installation of New Performance System

(Hint: Do not fully tighten any clamps until the complete system is installed and aligned.)

- 1) Install the adapter on the outlet of the converter with a clamp.
- 2) Install the "Y" pipe into the outlet of the muffler with a clamp. (The "Y" pipe is installed vertically.)
- 3) Hang the muffler in the stock location using the hanger clamp on the upper outlet of the y-pipe muffler. This determines the placement of the rest of the system.
- 4) Measure between the outlet of the adapter and the inlet of the muffler. Add 5" to this measurement for the slip joints and cut the straight pipe to fit. Install the cut pipe between the adapter and the muffler with a clamp at front and a clamp on the muffler inlet. Install the hanger clamp in the stock location.
- 5) Install the first section tail pipe into the upper outlet of the "Y" pipe using the hanger clamp all ready installed. Rotate the pipe as needed to pass next to the shock absorber and over the rear axle on the driver's side.
- 6) Install the other first section tail pipe into the lower outlet of the "Y" pipe with a clamp. Rotate the pipe as needed to pass next to the shock absorber and over the rear axle on the passenger's side.
- 7) Install both second section tail pipes into the outlets of the over-the-axle tail pipes with a clamp at each joint. Rotate as needed to level the outlet behind the rear tires.
- 8) Install the hanger brackets in the existing hole in the frame rail on the driver's side and passenger's side. Install the rubber mounts to the hanger brackets using the bolts supplied.
- 9) Install the hanger clamps on the tail pipes using the installed rubber hangers.
- 10) Starting at the turbo, align and tighten all the pipes and clamps. Start the engine and check for leaks.

Rev. MPN 6-25-07

#### **\*\*Disclaimer\*\***

This application was designed as a performance cosmetic upgrade. Towing a 5<sup>th</sup> wheel or bumper tow trailer with more than 500 lbs. tongue weight may result in damage to your vehicle and/or the exhaust system